

DZ210

Monitor for direction of rotation and standstill

Product features:

- Simple and compact unit to monitor forward / reverse motion and standstill of machines
- Universal pulse inputs for use with all common incremental encoders and sensors (HTL, RS422 or TTL)
- Two potential-free changeover relay outputs as well as two fast-responding power transistor outputs
- Wide input frequency range (up to 500 kHz) and a fast response time (<1 msec. with $f > 1$ kHz)
- Compact housing for simple snap fitting on top hat rails (EN 60715)
- Easy to set up by two front DIL switches
- 17 to 30 VDC power supply

Version:	Description:
DZ21001a/af/hk_Aug2007	First edition
DZ21001b/tj/nw_Feb2014	Correction in chapter 3.3. "Impulse Inputs"
Dz210_01c_oi/Nov-15/ag	"Safety Instructions" and "Legal notices" supplemented "Technical Specifications" and manual-design updated

Legal notices:
All contents included in this manual are protected by the terms of use and copyrights of motrona GmbH. Any reproduction, modification, usage or publication in other electronic and printed media as well as in the internet requires prior written authorization by motrona GmbH.

Table of Contents

1. Safety Instructions and Responsibility	3
1.1. General Safety Instructions.....	3
1.2. Use according to the intended purpose	3
1.3. Installation.....	4
1.4. Cleaning, Maintenance and Service Notes.....	4
2. Introduction	5
3. Connections and Terminal Assignments	5
3.1. Power Supply.....	6
3.2. Auxiliary Power Output	6
3.3. Impulse Inputs	6
3.4. Reset Input	6
3.5. Relay Outputs	6
3.6. Transistor Outputs.....	7
3.7. The front LEDs	7
4. Switch Settings	8
4.1. Setup of the Impulse Inputs	8
4.2. Basic Switching Functions	9
4.3. Setting of the Standstill Time (T)	10
4.4. Definition of Direction of Rotation	11
5. Technical Specifications	13
6. Dimensions.....	14

1. Safety Instructions and Responsibility

1.1. General Safety Instructions

This operation manual is a significant component of the unit and includes important rules and hints about the installation, function and usage. Non-observance can result in damage and/or impairment of the functions to the unit or the machine or even in injury to persons using the equipment!

Please read the following instructions carefully before operating the device and observe all safety and warning instructions! Keep the manual for later use.

A pertinent qualification of the respective staff is a fundamental requirement in order to use these manual. The unit must be installed, connected and put into operation by a qualified electrician.

Liability exclusion: The manufacturer is not liable for personal injury and/or damage to property and for consequential damage, due to incorrect handling, installation and operation. Further claims, due to errors in the operation manual as well as misinterpretations are excluded from liability.

In addition the manufacturer reserve the right to modify the hardware, software or operation manual at any time and without prior notice. Therefore, there might be minor differences between the unit and the descriptions in operation manual.

The raiser respectively positioner is exclusively responsible for the safety of the system and equipment where the unit will be integrated.

During installation or maintenance all general and also all country- and application-specific safety rules and standards must be observed.

If the device is used in processes, where a failure or faulty operation could damage the system or injure persons, appropriate precautions to avoid such consequences must be taken.

1.2. Use according to the intended purpose

The unit is intended exclusively for use in industrial machines, constructions and systems. Non-conforming usage does not correspond to the provisions and lies within the sole responsibility of the user. The manufacturer is not liable for damages which has arisen through unsuitable and improper use.

Please note that device may only be installed in proper form and used in a technically perfect condition (in accordance to the Technical Specifications, see chapter [5](#)). The device is not suitable for operation in explosion-proof areas or areas which are excluded by the EN 61010-1 standard.

1.3. Installation

The device is only allowed to be installed and operated within the permissible temperature range. Please ensure an adequate ventilation and avoid all direct contact between the device and hot or aggressive gases and liquids.

Before installation or maintenance, the unit must be disconnected from all voltage-sources. Further it must be ensured that no danger can arise by touching the disconnected voltage-sources.

Devices which are supplied by AC-voltages, must be connected exclusively by switches, respectively circuit-breakers with the low voltage network. The switch or circuit-breaker must be placed as near as possible to the device and further indicated as separator.

Incoming as well as outgoing wires and wires for extra low voltages (ELV) must be separated from dangerous electrical cables (SELV circuits) by using a double resp. increased isolation.

All selected wires and isolations must be conform to the provided voltage- and temperature-ranges. Further all country- and application-specific standards, which are relevant for structure, form and quality of the wires, must be ensured. Indications about the permissible wire cross-sections for wiring are described in the Technical Specifications (see chapter [5](#)).

Before first start-up it must be ensured that all connections and wires are firmly seated and secured in the screw terminals. All (inclusively unused) terminals must be fastened by turning the relevant screws clockwise up to the stop.

Overvoltages at the connections must be limited to values in accordance to the overvoltage category II.

For placement, wiring, environmental conditions as well as shielding and earthing/grounding of the supply lines the general standards of industrial automation industry and the specific shielding instructions of the manufacturer are valid. Please find all respective hints and rules on www.motrona.com/download.html --> "[General EMC Rules for Wiring, Screening and Earthing]".

1.4. Cleaning, Maintenance and Service Notes

To clean the front of the unit please use only a slightly damp (not wet!), soft cloth. For the rear no cleaning is necessary. For an unscheduled, individual cleaning of the rear the maintenance staff or assembler is self-responsible.

During normal operation no maintenance is necessary. In case of unexpected problems, failures or malfunctions the device must be shipped for back to the manufacturer for checking, adjustment and reparation (if necessary). Unauthorized opening and repairing can have negative effects or failures to the protection-measures of the unit.

2. Introduction

DZ210 has been designed as a monitor module for assembly in electrical control cabinets. The units are suitable for monitoring the direction of rotation and the zero-motion state with industrial machine applications.

As remarkable properties, the DZ210 units provide a very high input frequency range, a very fast response time and versatile settings for encoder characteristics and evaluation of the signals with respect to direction and standstill detection.

3. Connections and Terminal Assignments

The units provide a 9-position screw terminal strip on the bottom side for power supply and input signals, and three 3-position terminals on the top, for the outputs. The drawing below explains the function and assignment of the screw terminal strips.

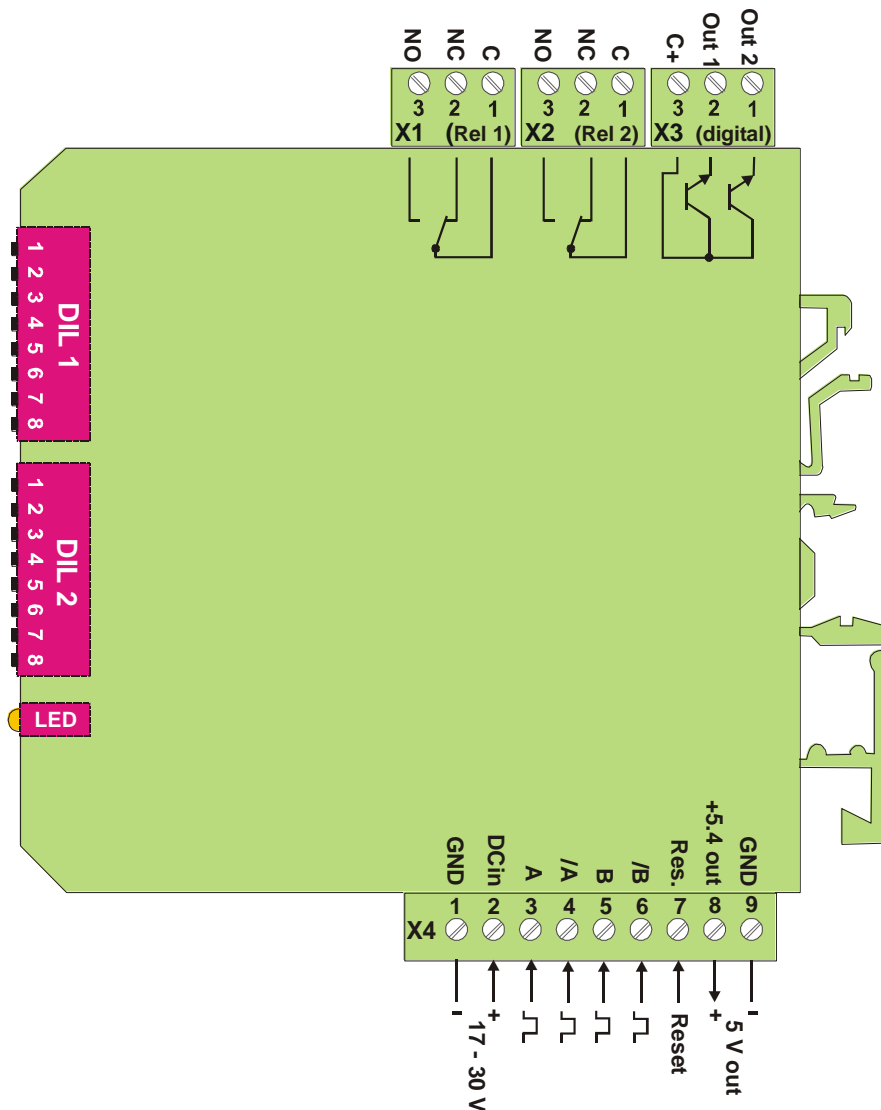

3.1. Power Supply

The unit operates with a DC power from 17 to 30 V, applied to terminals 1 and 2 of terminal strip X4. The power consumption is approx. 30 mA (plus about 30% of the current taken from the auxiliary 5 V output)

3.2. Auxiliary Power Output

Positions 8 and 9 of terminal strip X4 provide an auxiliary, stabilized 5 VDC output. The real output voltage is a little higher (e. g. 5.4 V) in order to compensate for voltage drop on connectors and cables. The auxiliary output is intended for supply of encoders and sensors. The output current must not exceed 200 mA.

3.3. Impulse Inputs

The unit features the input channels A, /A (A inverted), B and /B (B inverted). For detection the direction of rotation it is mandatory to apply at least signals A and B, with a distinguishable phase displacement (in general 90°). Inverted signals /A and /B are only needed with differential TTL inputs or RS422 input signals.

The inputs can be set by DIL switch to any of the following characteristics:

Impulse formats:

- HTL level 10 - 30 V
- TTL level (differential) respectively RS422 format (inverted signals included)
- TTL level single-ended (without inverted signals)

Switching characteristics:

- PNP (switching to +)
- NPN (switching to -)
- Tristate (Impedance 10 k)

3.4. Reset Input

A Reset input provides shutdown of all internal functions and forces the unit to "standstill" state. The switching characteristic of the Reset input is always HTL / PNP, i.e. you have to apply a positive signal (10 to 30 V) to effectuate the Reset state.

3.5. Relay Outputs

There are two output relays available (dry change-over contacts) with a switching capability of 30 VDC / 2 A respectively 230 VAC / 0.3 A. The response time of the relays is in a range of 5 msec.

Relay 1 (terminal X1) is always used to indicate the direction of rotation, according to the actual A / B phase situation. Relay 2 (terminal X2) can be set by DIL switch to either indicate the other direction of rotation, or to monitor "standstill"

3.6. Transistor Outputs

Both transistor outputs "Out1" und "Out2" (terminal X3) operate in parallel to the relay functions, but respond much faster (200 µsec only) than the relays.

The outputs are rated to switch DC voltage from 7 - 30 V at maximum currents of 350 mA (each).

The transistor outputs are 100% short-circuit-proof, however not both outputs must be short-circuited at the same time for a longer duration.

3.7. The front LEDs

The green LED on the front side of the unit signals that the unit is ready for operation. The yellow LED signals the input frequency, i.e. it will blink or be lit while the unit detects rotation, and it will be off when the unit detects standstill.

4. Switch Settings

4.1. Setup of the Impulse Inputs

Positions 1 to 5 of switch **DIL 1** are used to set levels and switching characteristics of the impulse inputs. Most of all practical applications would require one of the following three standard settings:

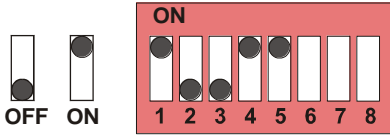
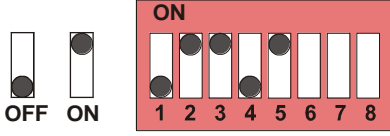
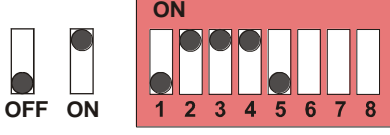
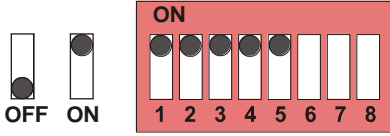
Input Signal	Setting DIL 1
RS422 or TTL symmetric (differential signals A, /A, B und /B)	
HTL signal, asymmetric, PNP (switch to +) (channels A and B only, no inverted signals)	
HTL signal, asymmetric, NPN (switch to -) (channels A and B only, no inverted signals) This setting is also suitable for NAMUR sensors (2-wire). Observe special hint below.	
TTL signal asymmetric (single-ended) (only A und B, no inverted signals)	

More combinations can be set with consideration of the individual function of each switch position, according to the following table:

1	OFF: HTL level (all of the 4 input lines)	ON: TTL level (all of the 4 input lines)
2	OFF: Input B is symmetric (needs /B)	ON: Input B is asymmetric (single-ended, no /B)
3	OFF: Input A is symmetric (needs /A)	ON: Input A is asymmetric (single-ended, no /A)
4	---	ON: internal pull-up resistor towards + *)
5	---	ON: internal pull-down resistor towards GND *)

*) Positions 4 and 5 both ON = Tristate, input impedance = 10 kOhms



- At any time one of the positions 4 and 5 must be "ON".
With 4 and 5 both OFF, the unit may produce undefined operations
- Unused inputs should always be set to HTL level
- With use of Namur (2-wire) sensors, please connect the positive wire to the corresponding input, and the negative wire to GND.
- With setting HTL and NPN all impulse inputs are tied to the positive potential of the power supply (+24 V) via internal pull-up resistors. To avoid damage with use of TTL encoders, it is advisable to first set the unit to TTL level prior to connection of the encoder to the unit.

4.2. Basic Switching Functions

Positions 6, 7 and 8 of switch DIL1 allow selecting the following functions:

	DIL 1	DIL 1
6	OFF: Standstill detection without post-trigger function (see clarification below)	ON: Standstill detection with post-trigger function (see clarification below)
7	OFF: Relay 2 and Out 2 to signal the opposite direction of the Rel1/Out1 indication	ON: Relay 2 and Out 2 to signal zero motion (standstill)
8	OFF: Upon detection of standstill, the direction signal is cleared (no indication)	ON: Upon detection of standstill, the information of the last actual direction remains active

The subsequent drawing explains the difference between "post trigger function on" and "post trigger function off".

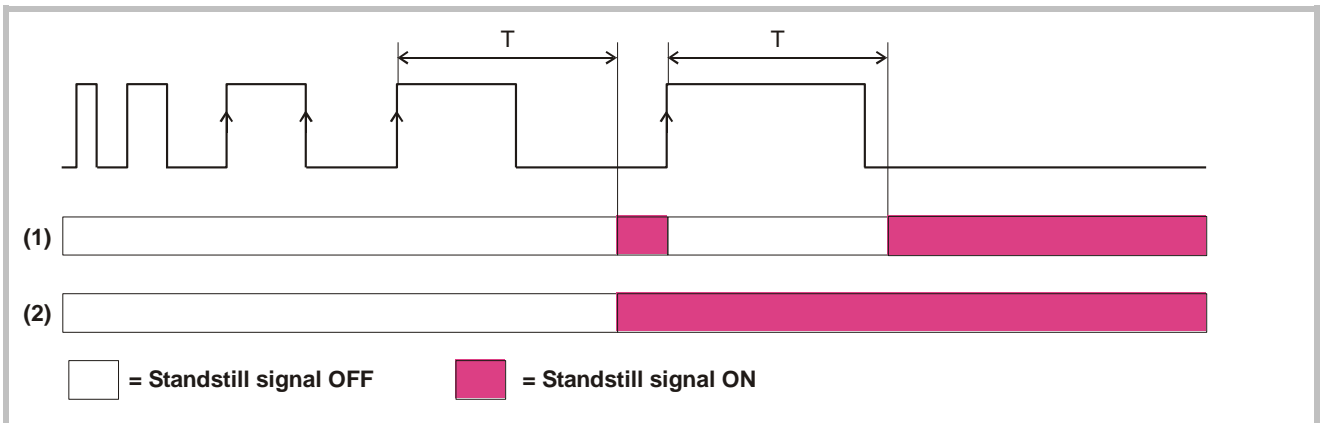

In order to get a standstill signal at all, the time distance between two positive edges must become greater than the setting "T".

- Case **(1)** shows the post-trigger on. The standstill signal immediately switches off again when another active edge is detected (no matter after which time). In this case, during slow-down of the machine, the output and the relay might therefore produce multiple on-off cycles before the standstill signal becomes stationary. However this method could be considered as "more safe", because it would detect any motion, no matter how slow it is.
- Case **(2)** shows the post-trigger off. After the standstill signal has switched on, it will remain on and only switch off again after two subsequent edges have been detected where the time distance was less than T.

4.3. Setting of the Standstill Time (T)

Provided that the standstill function has been assigned to relay 2 and output 2 by setting DIL switch 1 position 7 to ON, a standstill definition can be set by means of positions 1 - 4 of the switch DIL 2. The table indicates the pause time between two input pulses that must be exceeded in order to signal "standstill".

DIL 2		DIL 2	
1 msec		256 msec	
2 msec		512 msec	
4 msec		1.024 sec	
8 msec		2.048 sec	
16 msec		4.096 sec	
32 msec		8.192 sec	
64 msec		16.384 sec	
128 msec		32.768 sec	

4.4. Definition of Direction of Rotation

In order to achieve a stable indication of the actual direction of rotation even under vibration and mechanical oscillation, positions 5 - 8 of switch DIL 2 provide setting of an impulse window.

Before detecting a direction or changing the direction signal, the unit must receive a consecutive number of impulses in the corresponding direction. The table shows how to set the switches to define the number of impulses required for detection of the direction.

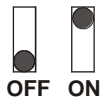
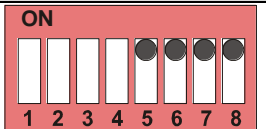
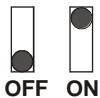
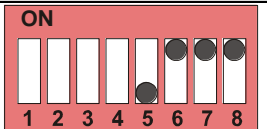
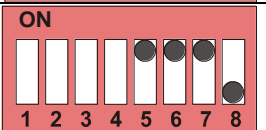
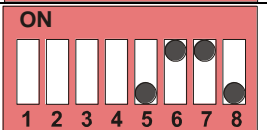
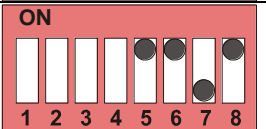
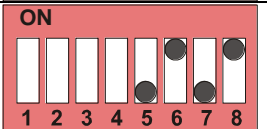
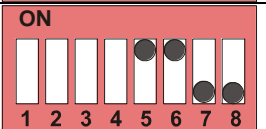
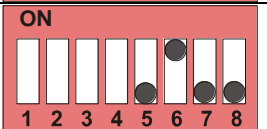
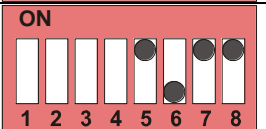
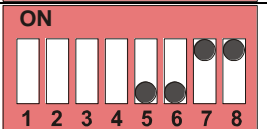
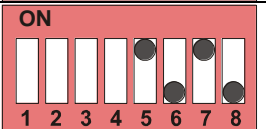
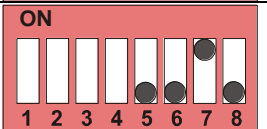
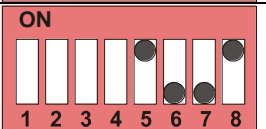
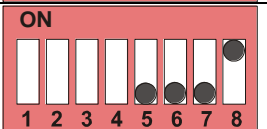
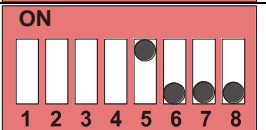
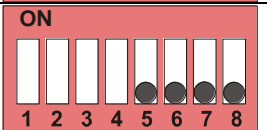
DIL 2		DIL 2			
1 Imp.			9 Imp.		
2 Imp.			10 Imp.		
3 Imp.			11 Imp.		
4 Imp.			12 Imp.		
5 Imp.			13 Imp.		
6 Imp.			14 Imp.		
7 Imp.			15 Imp.		
8 Imp.			16 Imp.		

The drawing below explains the operation of the direction outputs upon a change of direction.

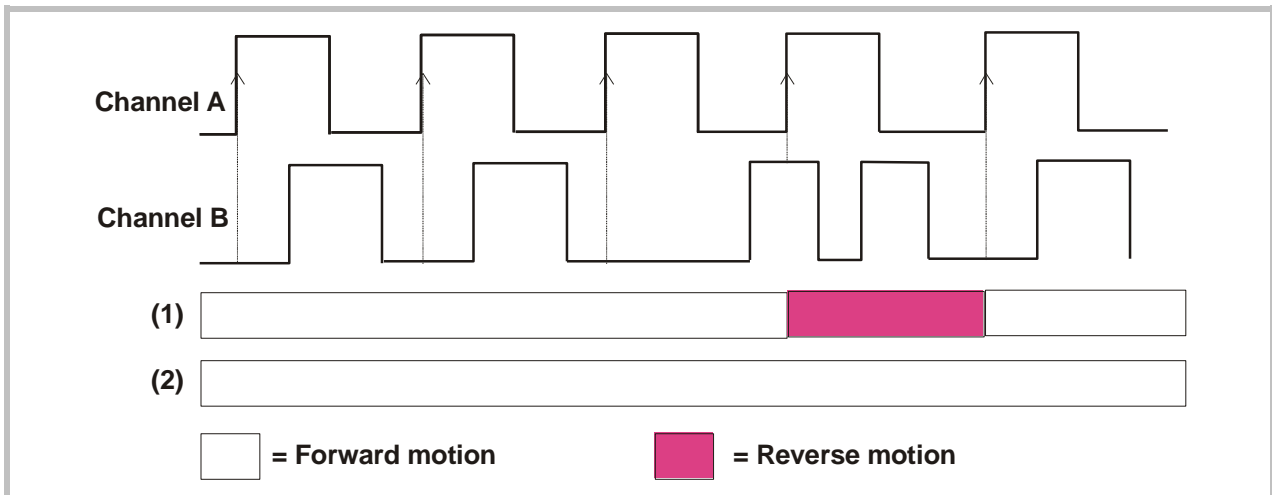

- With case (1) the window has been set to 1 impulse only. As a result the unit immediately changes the output already after the very first impulse into the opposite direction.
- With case (2) a window >1 has been set, wherewith the short change of the phase between channels A and B does not affect the direction signal.

5. Technical Specifications

Power supply:	Input voltage: 17 ... 30 VDC Protection circuit: reverse polarity protection Ripple: $\leq 10\%$ bei 24 VDC Consumption: approx. 30 mA (unloaded) Connections: screw terminal, 1.5 mm ² / AWG 16
Encoder supply:	Output voltage: approx. 5.4 V Output current: max. 200 mA Connections: screw terminal, 1.5 mm ² / AWG 16
Incremental input:	Characteristic: PNP, NPN Level: RS422: Differential voltage > 1 V TTL: LOW 0 ... 0.5 V, HIGH 2.5 ... 5 V HTL: LOW 0 ... 4 V, HIGH 9 ... 30 V Channels: A, /A, B, /B or A, B Frequency: RS422 and TTL: max. 500 kHz (symmetrical) HTL and TTL: max. 350 kHz (asymmetrical) Internal resistance: RS422 and TTL: $R_i \approx 10\text{ k}\Omega$ HTL: $R_i \approx 4.7\text{ k}\Omega$ Connections: screw terminal, 1.5 mm ² / AWG 16
Relay outputs:	Number of relays: 2 potential free changeovers Switching capacity: 30 VDC / 2 A or 115 VAC / 0.6 A or 230 VAC / 0.3 A Switching delay: approx. 5 ms Connections: screw terminal, 1.5 mm ² / AWG 16
Transistor outputs:	Number of outputs: 2 Type: High-Side-Driver Switching voltage: 7 ... 30 V Switching current: max. 350 mA Switching delay: approx. 200 μ s Protection circuit: durable short circuit proof (not both outputs at the same time!) Connections: screw terminal, 1.5 mm ² / AWG 16
Housing:	Material: plastic Mounting: 35 mm top hat rail (according to EN 60715) Dimensions (w x h x d): 22.5 x 102 x 102 mm / 0.8858 x 4.0157 x 4.0157 inch Protection class: IP20 Weight: approx. 100 g
Ambient temperature:	Operation: 0 °C ... +45 °C / +32 ... +113 °F (not condensing) Storage: -25 °C ... +70 °C / -13 ... +158 °F (not condensing)
Failure rate:	MTBF in years: 91.5 a (long-term usage at 60 °C / 140 °F)
Conformity & standards:	EMC 2004/108/EC: EN 61000-6-2, EN 61000-6-3, EN 61000-6-4 LV 2006/95/EC: EN 61010-1 RoHS 2011/65/EU: EN 50581

6. Dimensions

